

Seminar Project

Movement Simulation

- Implement muscles in a multi-body system of the leg
- Identify muscle parameters
- e. g. play soccer or balance on ground

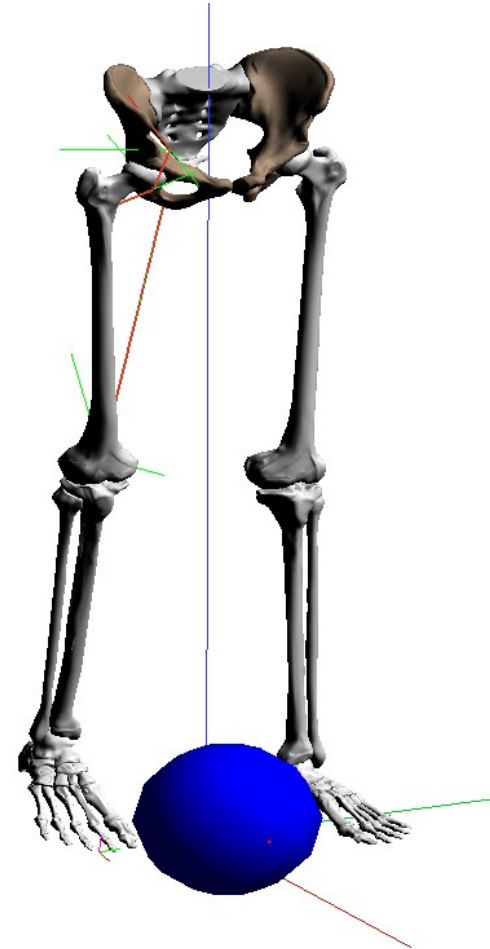

Seminar Project

Uncertainty in muscle modelling

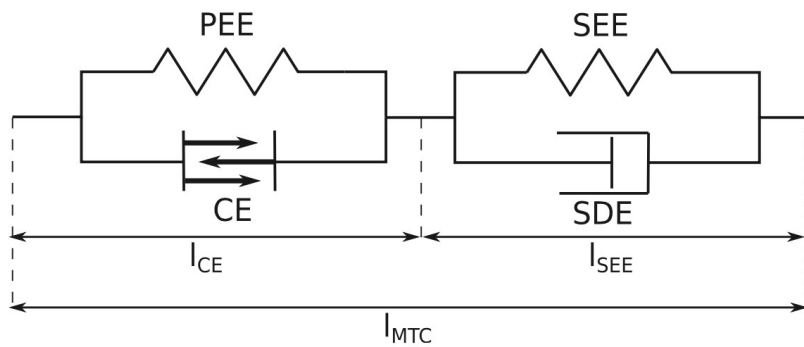

Haeufle et al. (2014)

Monte Carlo analysis of muscle parameters

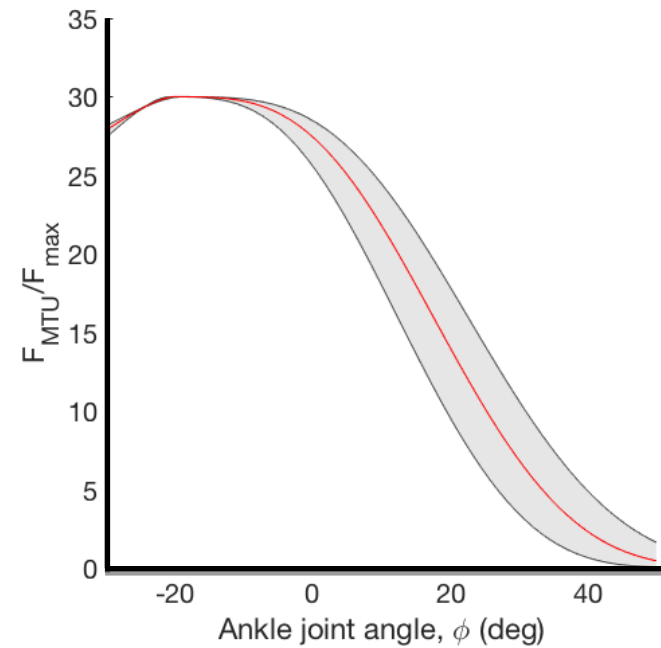

Seminar Project

EP-control on arm movements

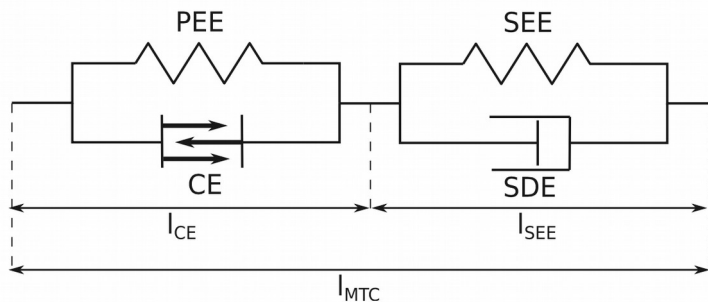

Haeufle et al. (2014)

$$u_i(\varphi_d, l_{CE,i}) = u_{i,open}(\varphi_d) + u_{i,closed}(\varphi_d, l_{CE,i})$$

$$u_{i,closed}(\varphi_d, l_{CE,i}) = \frac{k_p \cdot (\lambda_i(\varphi_d) - l_{CE,i}(t - \delta))}{l_{CE,opt,i}}$$

- Setup a SimMechanics Model of the arm with two muscles
- Implement EP control
- Study co-contraction

Seminar Project

Braitenberg Vehicles

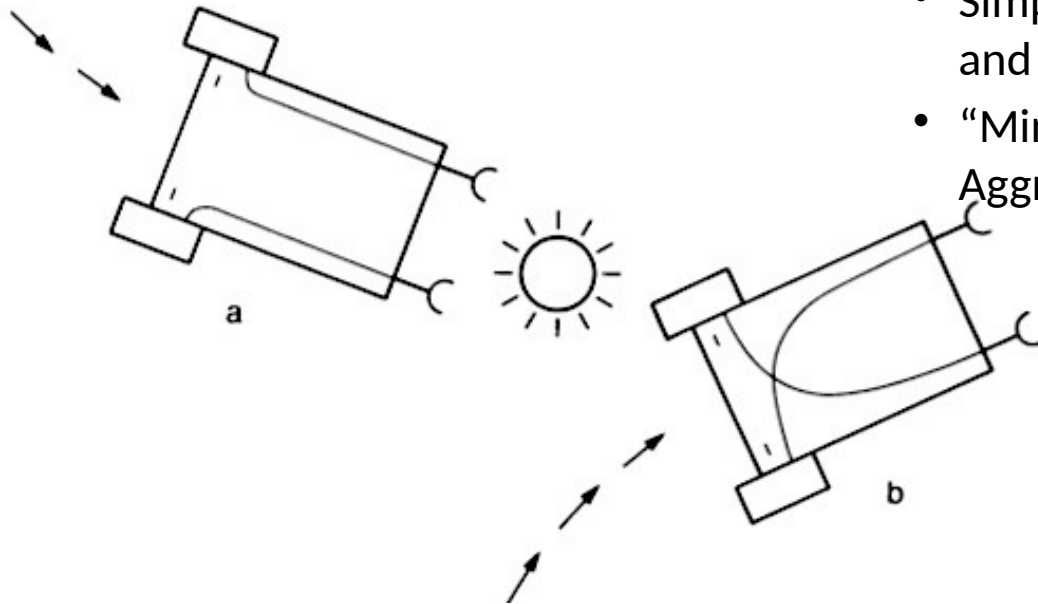

- Lego Mindstorms
- Simple connections between sensors and motors
- “Mimicry of emotions” (Love, Aggression, ...)

Seminar Project

Ataro Vision (?)

- Study vision and control of arm movement
- Identify point in space
- Find better coordinate system transformation

D. Driess, H. Zimmermann, S. Wolfen, D. Suissa, D. Haeufle, D. Hennes, M. Toussaint, S. Schmitt. Learning to Control Redundant Musculoskeletal Systems with Neural Networks and SQP: Exploiting Muscle Properties, In Proc. of the Int. Conf. on Robotics and Automation (ICRA), 2018.

